

BCS Editorial

The Genetics of Inherited Cardiac Conditions: New Expert Consensus

Katharine Thomas MRCP

Clinical Research Fellow
University of Oxford, United Kingdom

Editor Ahmed Adlan
Deputy Editor Evelyn Brown

November 2022

Introduction

Inherited cardiac conditions are diseases affecting the heart that are caused by genetic mutations. These divide broadly into two types: monogenic (or Mendelian) disorders and polygenic (or disorders with complex inheritance) (**Table 1**) (1, 2). More than 7000 genetic mutations causing disease have been identified (2). Though initially genetic testing was limited to single-gene testing, diagnostic yields have significantly improved with the advent of whole-exome sequencing and whole-genome sequencing (3, 4).

Despite these advances genetic testing remains complex. In Mendelian disorders, penetrance of the

Take Home Messages

- Inherited cardiac conditions are diseases with a genetic component. Identifying causative genetic variants can be complex.
- A recent multinational Expert Consensus Statement on genetic testing for cardiac disease has been published (2022).
- This statement provides clear guidelines on when and how to perform genetic testing for each condition.
- Patients must be counselled appropriately regarding the implications of genetic testing.

gene varies by individual and there is often heterogenous disease progression. Additionally, inappropriate testing can lead to over interpretation and false positives. In disorders of complex inheritance where many different genetic variants collectively produce a disease phenotype, genetic testing is generally not clinically applicable (1).

This editorial serves as a brief refresher on the use of genetic testing in inherited cardiac conditions, and provides an overview of the new 2022 Expert Consensus Statement for genetic testing for cardiac conditions compiled by the European Heart Rhythm Association (EHRA), Heart Rhythm Society (HRS), Asia Pacific Heart Rhythm Society (APHRS) and Latin American Heart Rhythm Society (LAHRS).

About the author

Katharine Thomas is a Cardiology Registrar in North West Thames and a British Heart Foundation Clinical Research Fellow and DPhil candidate at the Oxford Centre for Magnetic Resonance, University of Oxford. She graduated from King's College London. Her interests are in cardiac MRI and inherited cardiac conditions.



Table 1: Definitions of common terms within Inherited Cardiac Conditions (1, 5)

Term	Definition
Cascade screening (or predictive testing)	Genetic testing of family members of the proband
Confirmatory testing	Genetic testing performed to confirm the diagnosis in the proband
Genotype	Genetic make-up of an individual
Monogenic (or Mendelian) disorders	Disorders caused typically by a mutation in one or two genes, with a clear pattern of inheritance and family clusters of disease
Phenotype	Observable characteristics of an individual. Determined by genotype and by environmental factors
Polygenic disorders (or disorders with complex inheritance)	Disorders caused by multiple genetic mutations, where family clusters of disease are less pronounced
Proband	The first person within a family to be diagnosed with an inherited cardiac condition
Single-gene testing	Testing for causative genetic variants within one single gene
Whole-exome sequencing	The portion of the genome that encodes proteins (around 1% of the human genome)
Whole-genome sequencing	The entirety of the human genome

Expert Consensus Statement on the state of genetic testing for cardiac diseases

A recent Expert Consensus Statement on genetic testing has been published, which lays out clear guidelines on how and when to test in four main disease groups: inherited arrhythmia syndromes; cardiomyopathies; sudden or aborted cardiac death; and congenital heart disease (1, 6). Of note, the genetics of aortic disease were not covered within this Statement but guidance can be sought elsewhere (7).

The current Expert Consensus Statement is significantly more extensive than the previous statement now more than ten years old. It incorporates the large advances in knowledge and understanding of genetic testing (including whole-exome and whole-genome testing) and causative genetic variants, as well as our emerging understanding of polygenic conditions with complex inheritance patterns.

Genetic testing plays a different role in each condition. For some conditions such as arrhythmogenic ventricular cardiomyopathy

(previously known as arrhythmogenic right ventricular cardiomyopathy or ARVC), identification of a genetic variant is a major criterion for diagnosis. In others, such as long QT syndrome, identification of specific variants is useful for risk stratification and gene-specific management (1, 8). For some conditions, such as early repolarisation syndrome (previously termed benign early repolarisation), cardiac conduction disease and atrial fibrillation genetic testing can be less useful resulting in a higher threshold for testing.

Genetic testing for disease-causing variants

Testing for causative genetic variants is initially performed through specific “panels” (such as a dilated cardiomyopathy panel), which provides broad coverage of likely disease-causing variants for each condition. These are regularly updated as knowledge changes (1). In specific cases (i.e. very heterogenous conditions) testing can be extended to whole-exome or whole-genome sequencing. In all cases it is recommended that genetic testing must be preceded by adequate genetic counselling (9).

Table 2: Frequency of common disease-causing genetic variants identified in various inherited cardiac conditions (1)

Condition	Common causative genetic variants and frequency (%)
Cardiomyopathies	
Arrhythmogenic cardiomyopathy (ACM)*	PKP2 (20-45) DSP (2-15) DSG2 (4-15)
Dilated cardiomyopathy (DCM)	TTN (15-25) LMNA (4-7) MYH7 (3-5)
Hypertrophic cardiomyopathy (HCM)	MYBPC3 (40-45) MYH7 (15-25) TNNI3/TNNT2 (2-15)
Left ventricular non-compaction (LVNC)	MYH7 (10-15) MYBPC3 (5-15) TTN (5-10)
Arrhythmia syndromes	
Brugada syndrome (BrS)	SCN5A (20)
Catecholamine polymorphic ventricular tachycardia (CPVT)	RyR2 (60-70) CASQ2 (5)
Long QT syndrome	KCNQ1 (40-55) KCNH2 (30-45) SCN5A (5-10)
Sudden (or aborted) cardiac death	Miscellaneous ** (13-27)
* previously known as arrhythmogenic right ventricular cardiomyopathy (ARVC).	
** sudden (or aborted) cardiac death survivors (aged<35 years) may have coronary artery disease (~24%), inherited cardiomyopathy (~16%) or an inherited arrhythmia syndrome (~24%).	

A disease-causing variant is not always identified in patients with a disease phenotype (**Table 2**) (1, 10). The yield on genetic testing for dilated cardiomyopathy (DCM) is highly variable, reflecting the heterogeneity of DCM as a disease, and is highest in those with familial DCM or those with extra-cardiac signs.

“Missing heritability” is likely caused by a combination of many factors: the genetic variant may be very common (>1% in general population), or conversely very rare requiring whole-genome sequencing. There may also be environmental factors that are not adequately accounted for (11, 12).

Classification of genetic variants

Genetic variants are described using specific terminology. Any genetic variant found can be classified into five groups (**Table 3**) (13). Variants can be up- or downgraded as more is learned about whether the genetic variant correlates with the disease phenotype. Detection of a pathogenic or likely pathogenic variant is considered a positive result.

Table 3: Classification of genetic variants according to American College of Medical Genetics and Genomics (ACMG)

Classification	Definition
Pathogenic	Variant thought to be causative for the disease
Likely pathogenic	>90% certainty of variant causing disease
Variant of uncertain significance (VUS)	Variant has been identified, but it is not clear whether it is disease-causing
Likely benign	>90% certainty of variant being benign
Benign	Variant not thought to be causative for the disease

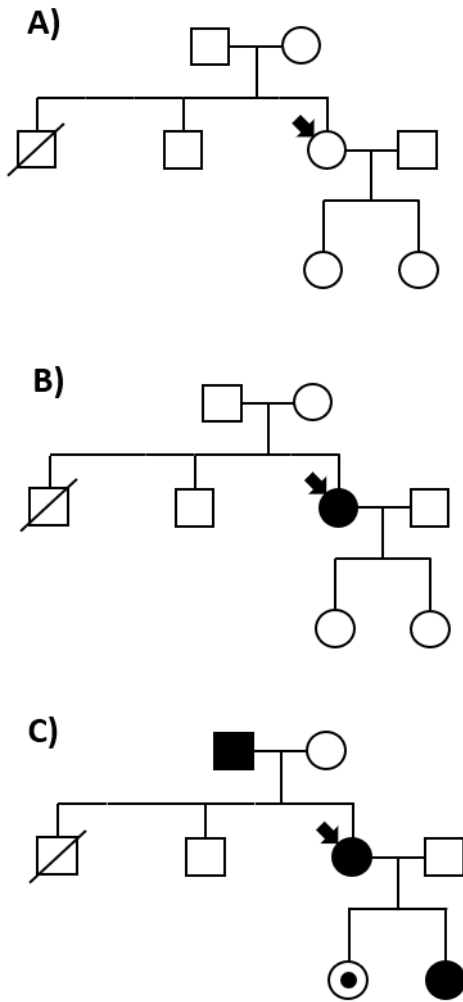

Figure 1. Illustrative example of a pedigree for an inherited cardiac condition.

A) The proband (indicated by arrow) is diagnosed with an inherited cardiac condition. B) The proband undergoes genetic testing and is found to have a disease-causing variant genetic mutation (confirmatory testing). C) Following identification of a disease-causing variant, family members are offered genetic testing to see if they may develop the disease (cascade screening/predictive testing) and a more complete pedigree can be determined. In this illustrative example, the proband's father and both daughters are both found to have the same disease-causing variant (genotype positive), but only the father and one daughter have clinical abnormalities consistent with the condition (phenotype positive). The other daughter has no clinical abnormalities, despite carrying the disease-causing variant (genotype positive but phenotype negative). One of the proband's brothers is deceased (diagonal crossed line), which may be as a result of an undiagnosed inherited cardiac condition.

Circle = female. Square = male. Diagonal crossed line = deceased family member. Black shading indicates individual is positive for genotype and phenotype. Black dot within centre indicates individual is positive for genotype but negative for phenotype.

The proband

The proband is defined as the first person within a family to be diagnosed with an inherited cardiac condition (**Figure 1**). This diagnosis can occur postmortem following sudden cardiac death. Once the diagnosis is made, genetic testing can be performed (even postmortem, if blood or tissue was collected at the time). For some conditions such as DCM, genetic testing is not performed unless there is also a clear family history of DCM, or there are signs suggestive of a genetic component (such as atrioventricular block, creatine phosphokinase elevation, extra-cardiac signs) (1). This form of genetic testing is called confirmatory testing.

Family members of the affected proband

If a pathogenic or likely pathogenic variant is identified in the proband, family members can be offered genetic testing to assess whether they may develop the disease. Genetic testing of family members of the proband is known as cascade screening or predictive testing.

Conclusions

Genetic testing in inherited cardiac conditions is a useful tool, but remains a complex area. When used properly genetic testing can guide diagnosis, risk stratification, and gene-specific management, as well as screening family members of an affected individual. The recent updated Expert Consensus Statement provides clear guidelines on when and how to test for each inherited cardiac condition.

Disclosures

KET acknowledges British Heart Foundation Clinical Research Training Fellowship (FS/CRTF/21/24268).

References

1. Wilde AAM, Semsarian C, Márquez MF, Shamloo AS, Ackerman MJ, Ashley EA, et al. European Heart Rhythm Association (EHRA)/Heart Rhythm Society (HRS)/Asia Pacific Heart Rhythm Society (APHRS)/Latin American Heart Rhythm Society (LAHRS) Expert Consensus Statement on the state of genetic testing for cardiac diseases. *Europace*. 2022;24(8):1307-67.
2. Claussnitzer M, Cho JH, Collins R, Cox NJ, Dermitzakis ET, Hurles ME, et al. A brief history of human disease genetics. *Nature*. 2020;577(7789):179-89.
3. Yang Y, Muzny DM, Reid JG, Bainbridge MN, Willis A, Ward PA, et al. Clinical whole-exome sequencing for the diagnosis of mendelian disorders. *N Engl J Med*. 2013;369(16):1502-11.
4. Jacob HJ. Next-generation sequencing for clinical diagnostics. *N Engl J Med*. 2013;369(16):1557-8.
5. NIH National Human Genome Research Institute 2022
6. Ackerman MJ, Priori SG, Willems S, Berul C, Brugada R, Calkins H, et al. HRS/EHRA expert consensus statement on the state of genetic testing for the channelopathies and cardiomyopathies: this document was developed as a partnership between the Heart Rhythm Society (HRS) and the European Heart Rhythm Association (EHRA). *Europace*. 2011;13(8):1077-109.
7. Members ATF, Erbel R, Aboyans V, Boileau C, Bossone E, Bartolomeo RD, et al. 2014 ESC Guidelines on the diagnosis and treatment of aortic diseases: Document covering acute and chronic aortic diseases of the thoracic and abdominal aorta of the adultThe Task Force for the Diagnosis and Treatment of Aortic Diseases of the European Society of Cardiology (ESC). *European Heart Journal*. 2014;35(41):2873-926.
8. Musunuru K, Hershberger RE, Day SM, Klinedinst NJ, Landstrom AP, Parikh VN, et al. Genetic Testing for Inherited Cardiovascular Diseases: A Scientific Statement From the American Heart Association. *Circulation: Genomic and Precision Medicine*. 2020;13(4):e000067.
9. Charron P, Arad M, Arbustini E, Basso C, Bilinska Z, Elliott P, et al. Genetic counselling and testing in cardiomyopathies: a position statement of the European Society of Cardiology Working Group on Myocardial and Pericardial Diseases. *Eur Heart J*. 2010;31(22):2715-26.
10. Schwartz PJ, Ackerman MJ, Antzelevitch C, Bezzina CR, Borggrefe M, Cuneo BF, et al. Inherited cardiac arrhythmias. *Nat Rev Dis Primers*. 2020;6(1):58.
11. Manolio TA, Collins FS, Cox NJ, Goldstein DB, Hindorff LA, Hunter DJ, et al. Finding the missing heritability of complex diseases. *Nature*. 2009;461(7265):747-53.
12. Specterman MJ, Behr ER. Cardiogenetics: the role of genetic testing for inherited arrhythmia syndromes and sudden death. *Heart*. 2022.
13. Richards S, Aziz N, Bale S, Bick D, Das S, Gastier-Foster J, et al. Standards and guidelines for the interpretation of sequence variants: a joint consensus recommendation of the American College of Medical Genetics and Genomics and the Association for Molecular Pathology. *Genet Med*. 2015;17(5):405-24.